



Cubis® II

The New Generation of Modular Premium Balances

Highlights

- Leading performance. Monolithical weighing system, integrated climate sensors, individual sample holders
- Error-free operation. Individual QApp workflows, motorized auto-leveling*
- Full end-to-end data integrity. 21 CFR Part 11 compliance, integrated audit-trail, state-of-the-art user management
- Outstanding service support. Integrated status center, integrated service functions preventive maintenance on accredited standards

* For all models up to a maximum capacity of 8.2 kg



Product Information

The modular weighing system Cubis® II can be individually configured from different components. The combinability of the display unit, weighing module, draft shield, software packages for various applications and functions and a comprehensive range of accessories allows the individual adaptation of the Cubis® II balance to all weighing tasks. The Cubis® II range of premium laboratory balances with a maximum load between 2.1 g and 70 kg and a readability between 0.1 µg to 1 g provide the ideal model for every application.

Cubis® II Display and Control Units



Type	MCA
Display	Large high end 7" color touch TFT display in 16:9 format with new user interface
Software	Factory installed basic set of essential weighing applications (license free) and Packages with special weighing applications and function extensions (license required)
Operation	Activated by touch key, touch-free using IR sensor (draft shield M) or gesture sensor (optional), learning capability



Type	MCE
Display	State of the art TFT touch screen operation with brilliant, readable, display but uncomplex, easy to operate user interface
Software	Factory installed basic set of essential weighing applications
Operation	Activated by touch key, touch-free using IR sensor (draft shield M) or gesture sensor (optional), learning capability

Technical Specifications

Cubis® II Weighing Modules Ultra-Micro Balances 0.0001 mg

		2.7S
Scale interval (d)	mg	0.0001
Maximum capacity (Max)	g	2.1
Repeatability at 5 % load		
Standard deviation of the load values, tolerance	mg	0.0002
Standard deviation of the load values, typical value	mg	0.00015
Repeatability near Max		
Standard deviation of the load values, tolerance	mg	0.00025
Standard deviation of the load values, typical value	mg	0.00018
Linearity Deviation		
Tolerance	mg	0.0009
Typical value	mg	0.0007
Deviation at eccentric loading, positions according to OIML R76		
Test weight	g	1
Tolerance	mg	0.0007
Typical value	mg	0.0005
Sensitivity drift between +10 °C and +30 °C	ppm/K	1
Tare maximum capacity: Less than 100 % of maximum capacity		
Accuracy class according to Directive 2014/31/EU		I
Verification scale interval (e) according to Directive 2014/31/EU	mg	1
Minimum load (Min) according to Directive 2014/31/EU	mg	0.01
Minimum weight according to USP (United States Pharmacopeia), Chap. 41		
Optimum minimum weight	mg	0.082
Typical minimum weight	mg	0.3
Typical stabilization time	s	7
Typical measurement time	s	10
Recommended calibration weight		
External test load	g	2
Accuracy class, acc. to OIML R111-1		E2
Dimensions		
MCE/MCA Weighing module (L x W x H)*	mm	340 x 139 x 129
MCE Electronics module (L x W x H)	mm	315 x 240 x 61
MCA Electronics module (L x W x H)	mm	355 x 240 x 61
Weighing pan size	mm	Ø 20
Filter weighing pan	mm	Ø 50
Weight, approx.*	kg	6.4/7.1

* depending upon weighing pan size, filter weighing pan and draft shield

Cubis® II Weighing Modules
Micro Balances 0.001 mg

		10.6S	6.6S	3.6P
Scale interval (d)	mg	0.001	0.001	0.001 0.002 0.005
Maximum capacity (Max)	g	10.1	6.1	1.1 2.1 3.1
Repeatability at 5 % load				
Standard deviation of the load values, tolerance	mg	0.001	0.001	0.003
Standard deviation of the load values, typical value	mg	0.0005	0.0005	0.0005
Repeatability near Max				
Standard deviation of the load values, tolerance	mg	0.001	0.001	0.005
Standard deviation of the load values, typical value	mg	0.0006	0.0006	0.0006
Linearity Deviation				
Tolerance	mg	0.004	0.004	0.004
Typical value	mg	0.003	0.003	0.003
Deviation at eccentric loading, positions according to OIML R76				
Test weight	g	5	2	1
Tolerance	mg	0.004	0.004	0.005
Typical value	mg	0.003	0.003	0.003
Sensitivity drift between +10 °C and +30 °C	ppm/K	1	1	1
Tare maximum capacity: Less than 100 % of maximum capacity				
Accuracy class according to Directive 2014/31/EU		I	I	I
Verification scale interval (e) according to Directive 2014/31/EU	mg	1	1	1
Minimum load (Min) according to Directive 2014/31/EU	mg	0.1	0.1	0.1
Minimum weight according to USP (United States Pharmacopeia), Chap. 41				
Optimum minimum weight	mg	0.82	0.82	0.82
Typical minimum weight	mg	0.82	0.82	0.82
Typical stabilization time	s	5	5	5
Typical measurement time	s	8	8	8
Recommended calibration weight				
External test load	g	10	5	3
Accuracy class, acc. to OIML R111-1		E2	E2	E2
Dimensions				
MCE/MCA Weighing module (L x W x H)*	mm	340 x 139 x 129	340 x 139 x 129	340 x 139 x 129
MCE Electronics module (L x W x H)	mm	315 x 240 x 61	315 x 240 x 61	315 x 240 x 61
MCA Electronics module (L x W x H)	mm	355 x 260 x 61	355 x 260 x 61	355 x 260 x 61
Weighing pan size	mm	Ø 30	Ø 30	Ø 30
Filter weighing pan	mm	Ø 50	Ø 50	Ø 50
Weight, approx.*	kg	6.4/7.1	6.4/7.1	6.4/7.1

* depending upon weighing pan size, filter weighing pan and draft shield

Cubis® II Weighing Modules
Semi-Micro Balances 0.01 mg

		225S	225P	125S	125P
Scale interval (d)	mg	0.01	0.01 0.02 0.05	0.01	0.01 0.1
Maximum capacity (Max)	g	220	60 120 220	120	60 120
Repeatability at 5 % load					
Standard deviation of the load values, tolerance	mg	0.015	0.015	0.015	0.015
Standard deviation of the load values, typical value	mg	0.01	0.01	0.01	0.01
Repeatability near Max					
Standard deviation of the load values, tolerance	mg	0.025	0.04	0.025	0.06
Standard deviation of the load values, typical value	mg	0.02	0.02	0.02	0.02
Linearity Deviation					
Tolerance	mg	0.1	0.15	0.1	0.15
Typical value	mg	0.065	0.1	0.065	0.1
Deviation when load is off-center, positions according to OIML R76					
Test weight	g	100	100	50	50
Tolerance	mg	0.15	0.2	0.15	0.2
Typical value	mg	0.1	0.1	0.1	0.1
Sensitivity drift between +10 °C and +30 °C	ppm/K	1	1	1	1
Tare maximum capacity: Less than 100 % of maximum capacity					
Accuracy class according to Directive 2014/31/EU		I	I	I	I
Verification scale interval (e) according to Directive 2014/31/EU	mg	1	1	1	1
Minimum load (Min) according to Directive 2014/31/EU	mg	1	1	1	1
Minimum weight according to USP (United States Pharmacopeia), Chap. 41					
Optimum minimum weight	mg	8.2	8.2	8.2	8.2
Typical minimum weight	mg	13	13	13	13
Typical stabilization time	s	2	2	2	2
Typical measurement time	s	6	6	6	6
Recommended calibration weight					
External test load	g	200	200	100	100
Accuracy class, acc. to OIML R111-1		E2	E2	E2	E2
Dimensions					
MCE/MCA Weighing module (L x W x H)*	mm	404 x 240 x 373			
MCE Electronics module (L x W x H)	mm	315 x 240 x 61			
MCA Electronics module (L x W x H)	mm	355 x 240 x 61			
Weighing pan size	mm	85 x 85			
Weight, approx.*	kg	10.2/11.7			

* depending upon weighing pan size, filter weighing pan and draft shield

Cubis® II Weighing Modules
Analytical Balances 0.1 mg

		524S	524P	324S	324P	224S	124S
Scale interval (d)	mg	0.1	0.1 0.2 0.5	0.1	0.1 0.2 0.5	0.1	0.1
Maximum capacity (Max)	g	520	120 240 520	320	80 160 320	220	120
Repeatability at 5 % load							
Standard deviation of the load values, tolerance	mg	0.08	0.08	0.08	0.08	0.07	0.1
Standard deviation of the load values, typical value	mg	0.04	0.04	0.04	0.04	0.05	0.05
Repeatability near Max							
Standard deviation of the load values, tolerance	mg	0.1	0.15	0.1	0.1	0.07	0.1
Standard deviation of the load values, typical value	mg	0.05	0.05	0.05	0.05	0.05	0.05
Linearity Deviation							
Tolerance	mg	0.4	0.5	0.3	0.5	0.2	0.2
Typical value	mg	0.2	0.2	0.2	0.2	0.13	0.13
Deviation when load is off-center, positions according to OIML R76							
Test weight	g	200	200	200	200	100	50
Tolerance	mg	0.3	0.4	0.3	0.4	0.2	0.2
Typical value	mg	0.2	0.2	0.2	0.2	0.12	0.12
Sensitivity drift between +10 °C and +30 °C	ppm/K	1	1	1	1	1	1
Tare maximum capacity: Less than 100 % of maximum capacity							
Accuracy class according to Directive 2014/31/EU		I	I	I	I	I	I
Verification scale interval (e) according to Directive 2014/31/EU	mg	1	1	1	1	1	1
Minimum load (Min) according to Directive 2014/31/EU	mg	10	10	10	10	10	10
Minimum weight according to USP (United States Pharmacopeia), Chap. 41							
Optimum minimum weight	mg	82	82	82	82	82	82
Typical minimum weight	mg	82	82	82	82	100	100
Typical stabilization time	s	1	1	1	1	1	1
Typical measurement time	s	3	3	3	3	3	3
Recommended calibration weight							
External test load	g	500	500	300	300	200	100
Accuracy class, acc. to OIML R111-1		E2	E2	E2	E2	E2	E2
Dimensions							
Weighing module (L × W × H)*	mm	425 x 240 x 373					
Weighing pan size	mm	85 x 85					
Weight, approx.*	kg	8.2/10.0					

* depending upon weighing pan size, filter weighing pan and draft shield

Cubis® II Weighing Modules
Precision Balances

		5203S	5203P	3203S	2203S	2203P	1203S
Scale interval (d)	mg	1	1 2 5	1	1	1 10	1
Maximum capacity (Max)	g	5200	1200 2400 5200	3200	2200	1010 2200	1200
Repeatability at 5 % load							
Standard deviation of the load values, tolerance	mg	1	1	1	0.7	0.7	0.7
Standard deviation of the load values, typical value	mg	0.6	0.6	0.6	0.5	0.5	0.5
Repeatability near Max							
Standard deviation of the load values, tolerance	mg	1	1	1	1	1	0.7
Standard deviation of the load values, typical value	mg	0.6	0.6	0.6	0.6	0.6	0.6
Linearity Deviation							
Tolerance	mg	5	5	5	3	5	2
Typical value	mg	2	3	2	2	3	1
Deviation when load is off-center, positions according to OIML R76							
Test weight	g	2000	2000	1000	1000	1000	500
Tolerance	mg	2	2	2	2	3	2
Typical value	mg	1	1	1	1	2	1
Sensitivity drift between +10 °C and +30 °C	ppm/K	1	1	1	1	1	1.5
Tare maximum capacity: Less than 100 % of maximum capacity							
Accuracy class according to Directive 2014/31/EU		I	I	I	I	I	I
Verification scale interval (e) according to Directive 2014/31/EU	mg	10	10	10	10	10	10
Minimum load (Min) according to Directive 2014/31/EU	mg	100	100	100	100	100	100
Minimum weight according to USP (United States Pharmacopeia), Chap. 41							
Optimum minimum weight	mg	820	820	820	820	820	820
Typical minimum weight	mg	1200	1200	1200	1000	1000	1000
Typical stabilization time	s	1	1	1	1	1	1
Typical measurement time	s	2	2	2	1.5	1.5	1.5
Recommended calibration weight							
External test load	g	5000	5000	3000	2000	1000	1000
Accuracy class, acc. to OIML R111-1		E2	E2	E2	E2	E2	E2
Dimensions							
Weighing module (L x W x H)*	mm	425 x 240 x 122/284/373					
Weighing pan size	mm	140 x 140					
Weight, approx.*	kg	5.9/7.5/9.4/10.2					

* depending upon weighing pan size, filter weighing pan and draft shield

Cubis® II Weighing Modules
Precision Balances

		623S	623P	323S	14202S	14202P
Scale interval (d)	mg	1	1 / 2 / 5	1	10	10 20 50
Maximum capacity (Max)	g	620	150 300 620	320	14200	3500 7000 14200
Repeatability at 5 % load						
Standard deviation of the load values, tolerance	mg	0.7	1	0.7	10	10
Standard deviation of the load values, typical value	mg	0.4	0.4	0.4	5	5
Repeatability near Max						
Standard deviation of the load values, tolerance	mg	0.7	1	0.7	10	10
Standard deviation of the load values, typical value	mg	0.5	0.5	0.5	5	5
Linearity Deviation						
Tolerance	mg	2	5	2	30	50
Typical value	mg	0.6	1.5	0.6	10	20
Deviation when load is off-center, positions according to OIML R76						
Test weight	g	200	200	200	5000	5000
Tolerance	mg	2	4	2	20	40
Typical value	mg	1	3	1	10	10
Sensitivity drift between +10 °C and +30 °C	ppm/K	2	2	2	1.5	1.5
Tare maximum capacity: Less than 100 % of maximum capacity						
Accuracy class according to Directive 2014/31/EU		II	II	II	II	II
Verification scale interval (e) according to Directive 2014/31/EU	mg	10	10	10	100	100
Minimum load (Min) according to Directive 2014/31/EU	mg	20	20	20	1000	1000
Minimum weight according to USP (United States Pharmacopeia), Chap. 41						
Optimum minimum weight	mg	820	820	820	8200	8200
Typical minimum weight	mg	820	820	820	8200	8200
Typical stabilization time	s	0.8	0.8	0.8	0.8	0.8
Typical measurement time	s	1	1	1	1.5	1.5
Recommended calibration weight						
External test load	g	500	500	200	14000	14000
Accuracy class, acc. to OIML R111-1		E2	E2	E2	E2	E2
Dimensions						
Weighing module (L × W × H)*	mm	425 x 240 x 122/284/373			425 x 240 x 95	
Weighing pan size	mm	140 x 140			206 x 206	
Weight, approx.*	kg	5.9/7.5/9.4/10.2			5.4	

* depending upon weighing pan size, filter weighing pan and draft shield

Cubis® II Weighing Modules
Precision Balances

		10202S	8202S	6202S	6202P	5202S	4202S	2202S	
Scale interval (d)	mg	10	10	10	10 20 50	10	10	10	
Maximum capacity (Max)	g	10200	8200	6200	1500 3000 6200	5200	4200	2200	
Repeatability at 5 % load									
Standard deviation of the load values, tolerance	mg	7	7	7	7	6	7	7	
Standard deviation of the load values, typical value	mg	5	4	4	4	2	4	4	
Repeatability near Max									
Standard deviation of the load values, tolerance	mg	7	7	7	40	6	7	7	
Standard deviation of the load values, typical value	mg	5	4	4	15	2	4	4	
Linearity Deviation									
Tolerance	mg	20	20	20	50	10	20	20	
Typical value	mg	6	6	6	20	5	6	6	
Deviation when load is off-center, positions according to OIML R76									
Test weight	g	5000	5000	2000	2000	2000	2000	1000	
Tolerance	mg	20	30	20	30	10	30	20	
Typical value	mg	10	10	10	30	5	10	10	
Sensitivity drift between +10 °C and +30 °C	ppm/K	1.5	2	2	2	2	2	2	
Tare maximum capacity: Less than 100 % of maximum capacity									
Accuracy class according to Directive 2014/31/EU		II	II	II	II	I	II	II	
Verification scale interval (e) according to Directive 2014/31/EU	mg	100	100	100	100	100	100	100	
Minimum load (Min) according to Directive 2014/31/EU	mg	1000	500	500	500	1000	500	500	
Minimum weight according to USP (United States Pharmacopeia), Chap. 41									
Optimum minimum weight	mg	8200	8200	8200	8200	8200	8200	8200	
Typical minimum weight	mg	8200	8200	8200	8200	8200	8200	8200	
Typical stabilization time	s	0.8	1	1	1	0.8	1	0.8	
Typical measurement time	s	1.5	1.5	1.5	1.5	1	1	1	
Recommended calibration weight									
External test load	g	10000	7000	5000	5000	5000	3000	1500	
Accuracy class, acc. to OIML R111-1		E2	E2	E2	E2	E2	E2	E2	
Dimensions									
Weighing module (L × W × H)*	mm	425 x 240 x 95				425 x 240 x 122/284/373		425 x 240 x 95	
Weighing pan size	mm	206 x 206				140 x 140		206 x 206	
Weight, approx.*	kg	5.4				5.9/ 7.5/9.4/10.2		5.4	

* depending upon weighing pan size, filter weighing pan and draft shield

Cubis® II Weighing Modules
Precision Balances

		1202S	12201S	8201S	5201S
Scale interval (d)	mg	10	100	100	100
Maximum capacity (Max)	g	1200	12200	8200	5200
Repeatability at 5 % load					
Standard deviation of the load values, tolerance	mg	7	50	50	50
Standard deviation of the load values, typical value	mg	4	20	20	20
Repeatability near Max					
Standard deviation of the load values, tolerance	mg	7	50	50	50
Standard deviation of the load values, typical value	mg	4	20	20	20
Linearity Deviation					
Tolerance	mg	20	100	100	100
Typical value	mg	6	30	30	20
Deviation when load is off-center, positions according to OIML R76					
Test weight	g	500	5000	5000	2000
Tolerance	mg	20	200	200	200
Typical value	mg	10	100	100	100
Sensitivity drift between +10 °C and +30 °C	ppm/K	2	4	4	4
Tare maximum capacity: Less than 100 % of maximum capacity					
Accuracy class according to Directive 2014/31/EU		II	II	II	II
Verification scale interval (e) according to Directive 2014/31/EU	mg	100	1000	1000	1000
Minimum load (Min) according to Directive 2014/31/EU	mg	500	5000	5000	5000
Minimum weight according to USP (United States Pharmacopeia), Chap. 41					
Optimum minimum weight	mg	8200	82000	82000	82000
Typical minimum weight	mg	8200	82000	82000	82000
Typical stabilization time	s	0.8	0.8	0.8	0.8
Typical measurement time	s	1	1	1	1
Recommended calibration weight					
External test load	g	700	12000	8000	5000
Accuracy class, acc. to OIML R111-1		E2	F1	F1	F1
Dimensions					
Weighing module (L × W × H)*	mm	425 x 240 x 95			
Weighing pan size	mm	206 x 206			
Weight, approx.*	kg	5.4			

* depending upon weighing pan size, filter weighing pan and draft shield

Cubis® II Weighing Modules
High Capacity Balances

		32202P	70201S	50201S	36201S	36201P
Scale interval (d)	mg	10 100	100	100	100	100 1000
Maximum capacity (Max)	g	4200 32200	70200	50200	36200	10200 36200
Repeatability at 5 % load						
Standard deviation of the load values, tolerance	mg	40	100	100	100	100
Standard deviation of the load values, typical value	mg	20	40	40	20	20
Repeatability near Max						
Standard deviation of the load values, tolerance	mg	40 100	100	100	100	100
Standard deviation of the load values, typical value	mg	20 50	40	40	50	20
Linearity Deviation						
Tolerance	mg	200	500	500	200	200
Typical value	mg	100	150	150	100	100
Deviation when load is off-center, positions according to OIML R76						
Test weight	g	10000	20000	20000	10000	10000
Tolerance	mg	200	500	500	300	300
Typical value	mg	100	300	300	200	200
Sensitivity drift between +10 °C and +30 °C	ppm/K	2	2	2	2	2
Tare maximum capacity: Less than 100 % of maximum capacity						
Accuracy class according to Directive 2014/31/EU		-	II	II	II	II
Verification scale interval (e) according to Directive 2014/31/EU	mg	-	1000	1000	1000	1000
Minimum load (Min) according to Directive 2014/31/EU	mg	-	5000	5000	5000	5000
Minimum weight according to USP (United States Pharmacopeia), Chap. 41						
Optimum minimum weight	mg	8200	82000	82000	82000	82000
Typical minimum weight	mg	8200	82000	82000	82000	82000
Typical stabilization time	s	2	1.5	1.5	1.5	1.5
Typical measurement time	s	2	1.5	1.5	2	2
Recommended calibration weight						
External test load	g	30000	70000	50000	30000	30000
Accuracy class, acc. to OIML R111-1		F1	F1	F1	F1	F1
Dimensions						
Weighing module (L × W × H)*	mm	412 x 400 x 126/159				
Weighing pan size	mm	400 x 300/∅ 233				
Weight, approx.*	kg	15.8/17.1				

* depending upon weighing pan size, filter weighing pan and draft shield

Cubis® II Weighing Modules
High Capacity Balances

		20201S	11201S	70200S	36200S
Scale interval (d)	mg	100	100	1000	1000
Maximum capacity (Max)	g	20200	11200	70200	36200
Repeatability at 5 % load					
Standard deviation of the load values, tolerance	mg	100	100	500	500
Standard deviation of the load values, typical value	mg	20	20	200	200
Repeatability near Max					
Standard deviation of the load values, tolerance	mg	100	100	500	500
Standard deviation of the load values, typical value	mg	20	20	200	200
Linearity Deviation					
Tolerance	mg	200	200	1000	1000
Typical value	mg	60	60	200	200
Deviation when load is off-center, positions according to OIML R76					
Test weight	g	5000	5000	20000	10000
Tolerance	mg	300	300	1000	1000
Typical value	mg	200	200	600	500
Sensitivity drift between +10 °C and +30 °C	ppm/K	2	2	3	3
Tare maximum capacity: Less than 100 % of maximum capacity					
Accuracy class according to Directive 2014/31/EU		II	II	II	II
Verification scale interval (e) according to Directive 2014/31/EU	mg	1000	1000	10000	1000
Minimum load (Min) according to Directive 2014/31/EU	mg	5000	5000	50000	50000
Minimum weight according to USP (United States Pharmacopeia), Chap. 41					
Optimum minimum weight	mg	82000	82000	820000	820000
Typical minimum weight	mg	82000	82000	820000	820000
Typical stabilization time	s	1.5	1.5	1	1
Typical measurement time	s	2	2	1.2	1.2
Recommended calibration weight					
External test load	g	20000	10000	70000	30000
Accuracy class, acc. to OIML R111-1		F1	F1	F1	F1
Dimensions					
Weighing module (L × W × H)*	mm	412 x 400 x 126/159			
Weighing pan size	mm	400 x 300/∅ 233			
Weight, approx.*	kg	15.8/17.1			

* depending upon weighing pan size, filter weighing pan and draft shield

Accessories

Cubis® II Power Supply Unit

Only by Sartorius AC Adapter YEPS03-15V0

	Unit	Value
Primary		
AC voltage	V	100–240 (±10%)
Frequency	Hz	50–60 (±5%)
Current consumption, maximum	A	1.0
Secondary		
DC voltage at 2 A output current	V	14.25–15.75
Power, maximum	W	30
Short circuit protection: Electronic		
Protection class according to IEC 62368-1		I
Pollution level according to IEC 61010-1		2
Overvoltage category according to IEC 606641-1		II
Installation site according to IEC 62368-1, maximum altitude above sea level	m	5000
Temperature		
In operation	°C	0 – +40
During storage and transport	°C	-20 – +80
Connector for mains connection according to IEC 60320-1/C14: 3-pin		
Power supply cable		
Power supply cable according to IEC 60320-1/C14: Country-specific, 3-pin, two-sided plug		
Other data: See label on AC adapter		

Safety of Electrical Equipment

According to EN 61010-1/IEC 61010-1 Safety requirements for electrical equipment for measurement, control, and laboratory use
– Part 1: General Requirements

Electromagnetic Compatibility

Interference resistance

Suitable for use in industrial areas

Transient emissions

Class B

Suitable for use in residential areas and areas that are connected to a low voltage network that also supplies residential buildings.

Materials

Housing: Die-cast aluminum, plastic PBT, Optiwhite float glass and stainless steel 1.4401/1.4404, PA handles, aluminum trim
Control unit: Die-cast aluminum, painted, float glass and plastic PBT, PP

Integrated Clock

Maximum deviation per month (RTC): 30s

Backup Battery

Lithium battery: type CR2032

Service life at room temperature, minimum: 10 Years

Alibi Memory Value

Maximum number of data records: 150,000

Interfaces

Specifications for the COM-RS232 Interface

Type of interface: Serial interface

Interface operation: Full duplex

Level: RS232

Connection: D-sub connector, 9-pin

Pin assignment:

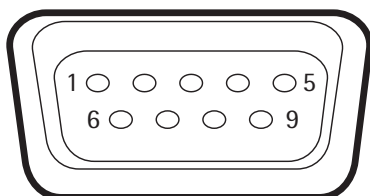

Pin 1: **Not** assigned

Pin 2: Data output (TxD)

Pin 3: Data input (RxD)

Pin 4: **Not** assigned

Pin 5: Internal ground

Pin 6: **Not** assigned

Pin 7: Clear to Send (CTS)

Pin 8: Request to Send (RTS)

Pin 9: **Not** assigned

Specifications for the USB-A Interface

Communication: USB host (master)

Connectable devices: Sartorius printers, USB sticks with software update

Specifications for the USB-B Interface

Communication: USB device (slave)

Type of interface: Virtual serial interface (virtual COM-port, VCP) and "PC direct" communication

Draft Shields

Code	Item
0	Flat, stainless steel weight pan with no draft shield for weighing modules.
A	Automatic, glass motorized draft shield with learning capability for user-friendly operation and easy customization to the changing requirements of different applications.
E	Manual glass draft shield for precision balances.
F	Manual stainless steel draft shield for weighing filters with diameters of up to 50 mm (75 mm and 90 mm pans optional).
I	Identical to the A draft shield, but also includes an integrated ionizer to eliminate interfering electrostatic charges on samples and sample containers.
M	Automatic, motorized, round 100% glass draft shield with learning capability for ultra-microbalance and microbalances.
R	Flat, stainless steel weighing pan draft shield (removable, with no glass components) for all precision balances
U	Manual glass analytical draft shield chamber, with smooth-action doors that open wide and provide unimpeded access to the weighing chamber without interfering braces.

Software

Code	Item
QP1	Q-App Package Pharma
QP2	Q-App Package Advanced Applications
QP3	Q-App Package Utilities
QP4	Q-App Package Connectivity

Ambient Conditions

	Unit	Value
Installation Site		
AC voltage	V	100–240 (±10%)
Frequency	Hz	50–60 (±5%)
Current consumption, maximum	A	1.0
Secondary		
Standard laboratory rooms		
Installation site according to IEC 60259-1, maximum altitude above sea level	m	3000
For indoor use only		
Temperature		
In operation	°C	+5 – +40
In operation for conformity-assessed devices: See information on the device's ID plate		
During storage and transport	°C	-20 – +60
Relative humidity		
At temperatures of up to 31 °C	%	80
Then linear decrease from 80 % at 31 °C to 50 % at 40 °C		
No heat from heating systems or direct sunlight		
No drafts from open windows, AC systems, or doors		
No vibrations		
No "heavy traffic" areas (personnel)		
No electromagnetic fields		
No dry air		

Meteorological Data

Code	Item
S00	Standard version non-verified, all units
S01	Standard version non-verified, metric units only
CCN	Balance with Type Approval Certificate for China
CEU	Verified balance with EC Type Approval Certificate (for EU except France)
CFR	Verified balance with EC Type Approval Certificate for France only
OBR	Balance with Type Approval Certificate for Brazil
OIN	Balance with Type Approval Certificate for India
OJP	Balance with Type Approval Certificate for Japan
ORU	Balance with Type Approval Certificate for Russia









Accessories

Printers and Communication	Quantity	Order number
Thermal transfer thermal printer for GLMP printouts on continuous paper and labels	1	YDP30
Laboratory thermal transfer printer YDP30 with USB and Ethernet connection (available Oct. 2019)	1	YDP30-NET
Wireless Nano USB Adapter (available Oct. 2019 in the EU only)	1	YWLAN01MS
WIFI Nano Router (available Oct. 2019 in the EU only)	1	YWLAN02MS
Standard paper and ink ribbon, set, 90 m, for YDP30	1	69Y03285
Self-adhesive paper and ink ribbon, 90 m, for YDP30	1	69Y03286
Standard thermal paper, 24 m roll, for YDP30 YDP40	5	69Y03287
Self-adhesive thermal paper, 13 m roll, for YDP30	5	69Y03288
Self-adhesive labels for YDP30		
58 mm × 100 mm	350	69Y03094
58 mm × 76 mm	500	69Y03093
58 mm × 30 mm	1000	69Y03092
Displays and Input/Output Elements	Quantity	Order number
MCE Display	1	69MS0218
Display head MCA for balances with automatic draft shield	1	69MS0212
Display head MCA for balances without automatic draft shield	1	69MS0215
MCA display for high-capacity balances (including short distance adapter)	1	69MS0216
Motion sensor for triggering a maximum of 4 functions via gesture control, selection via menu	1	YHS02MS
Display stand for weigh cells with scale interval of 100 mg 1 g and weighing capacity > 20 kg for raising the operating unit	1	YDH04MS
Display stand for weigh cells with scale interval of 10 mg 100 mg for raising the operating unit	1	YDH03MS
Barcode and QR Reader with USB (available Oct. 2019)	1	YBR05
Hardware for Pipette Calibration (Semi-Micro and Analytical balances)	Quantity	Order number
Pipette calibration kit (hardware). Consists of moisture trap and all required adapters	1	YCP04MS
Density Determination Kits	Quantity	Order number
Density determination kit for solids and liquids for 0.1 and 0.01 mg weighing modules	1	YDK03MS
Density determination kit for solids and liquids for 1 mg weighing modules	1	YDK04MS

Accessories (continued)

Filter Pans, Ionizer and Weighing Scoops	Quantity	Order number
Grid pan for model with a scale interval of 10 mg or 100 mg for weighing in laboratory hoods, safety barriers and workbenches, reduced wind attack surface of the weighing pan, replaces standard pan	1	YWP07MS
Anti-static weighing pan, 100 mm diameter, for weighing module for semi-microbalance and analytical balances with 0.1 mg or 0.01 mg scale interval	1	YWP04MS
Filter weighing pan made of Titanium, diameter 52 mm, for ultra-micro and micro-balances only together with F draft shield	1	YSH34
Filter weighing pan made of Titanium, diameter 75 mm, for ultra-micro balance or micro balance models only together with F draft shield	1	YSH35
Filter weighing pan made of Titanium, diameter 90 mm, for ultra-micro balance or micro balance models only together with F draft shield	1	YSH36
Ionization blower for electrostatically charged samples	1	YIB01-ODR
Ionizer with u-shaped electrode for 230 V	1	YIB02-230V
Ionizer with u-shaped electrode for 115 V	1	YIB02-115V
Stat-Pen ionization pen for discharging electrostatically charged samples	1	YSTP01
Aluminum weighing scoop, 4.5 mg for ultramicrobalance and microbalance models	250	6565-250
Aluminum weighing scoop, 52 mg for ultramicrobalance and microbalance models	50	6566-50
Weighing scoop made from chrome-nickel steel, L 90 mm x W 32 mm x H 8 mm	1	641214
Other Accessories	Quantity	Order number
Below-balance weighing hook for precision balances with scale interval of 100 mg 1 g and weighing capacity > 20 kg, not for verified models	1	69EA0040
Display cable, 3 m, for separate installation of display and weighing units, installation by Sartorius Service or at the factory	1	On request
RS232C connection cable, 9-pin, 3 m, for connection to a PC with 9-pin COM interface	1	On request
Sartorius Wedge, software for data communication between the PC and balance	1	YSW02
Display cable 3m	1	VF4754
Connection cable for eBox 1.2m / 2.5m	1	VF4755
Extension cable for climate tower 0.8m	1	VF4756
Extension cable for motion sensor 0.8m	1	VF4757
Connection cable for fermenter	1	VF4758
RS232-analog-converter	1	VF4759
MCA3203S-2S00-R for CeraCon	1	VF4760
RS232C connection cable	1	VF4761
Display cable 3m-10m	1	VF4762
Signal light incl. QApp	1	VF4763
Pipette calibration set micro balances	1	VF988
MC*36201S-000-DO with display 0.01g	1	VF4768
MC*20201S-000-DO with display 0.01g	1	VF4769
MC*70201S-000-DO with display 0.01g	1	VF4770
Cable RS232 25pin to M12 inlet	1	VF4766
Cable RS232 9 pin to M12 inlet	1	VF4767

Accessories (continued)

Weighing Tables		Quantity	Order number
Made from synthetic stone, with vibration dampening		1	YWT03
Made from wood with synthetic stone		1	YWT09
Wall console		1	YWT04
Climate Modules		Quantity	Order number
Climate module, uncalibrated, for draft shield A or I and user interface MCA		1	YCM20MC
Calibration of a climate module YCM20MC with DAkKS calibration certificate		1	YCM20DAkKS
Climate module with DAkKS calibration certificate for draft shield A or I and user interface MCA		1	YCM20MC-DAkKS
Tower for climate module, for mounting YCM20MC; can be ported to all Cubis II weighing modules with user interface MCA		1	YCM20MC-Tower
Titanium Holders for Ultra-Micro Balances and Micro Balances		Quantity	Order number
For coronary stents (up to 38 mm) (available October 2019)		1	YSH10
For save-lock tubes, 1.5 ml - 2 ml		1	YSH13
Titanium Holders for Semi-Micro Balances and Analytical Balances		Quantity	Order number
For save-lock tubes, 1.5 ml - 2 ml		1	YSH15
For save-lock tubes up to 5 ml		1	YSH19
For vials		1	YSH23
For weighing boats		1	YSH26
For filters, 150 mm diameter		1	YSH30
For titration vessels and round bottom flasks		1	YSH37
For syringes, vertical (available October 2019)		1	YSH46

Balance Dimensions

Ultra-Micro Balance

All dimensions are given in millimeters

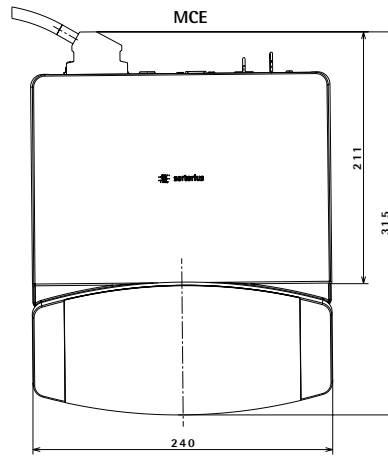
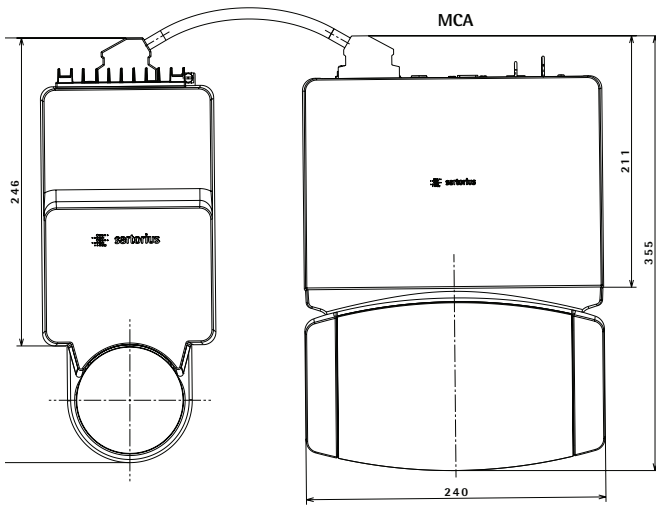
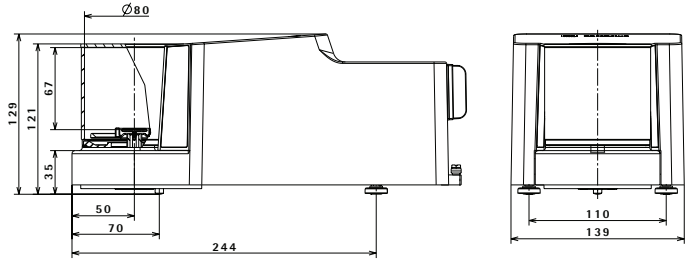
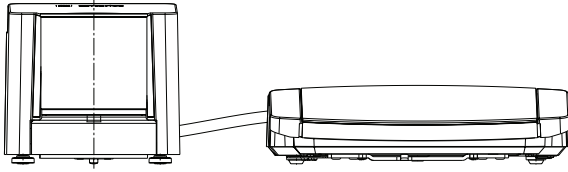

Micro Balance

All dimensions are given in millimeters

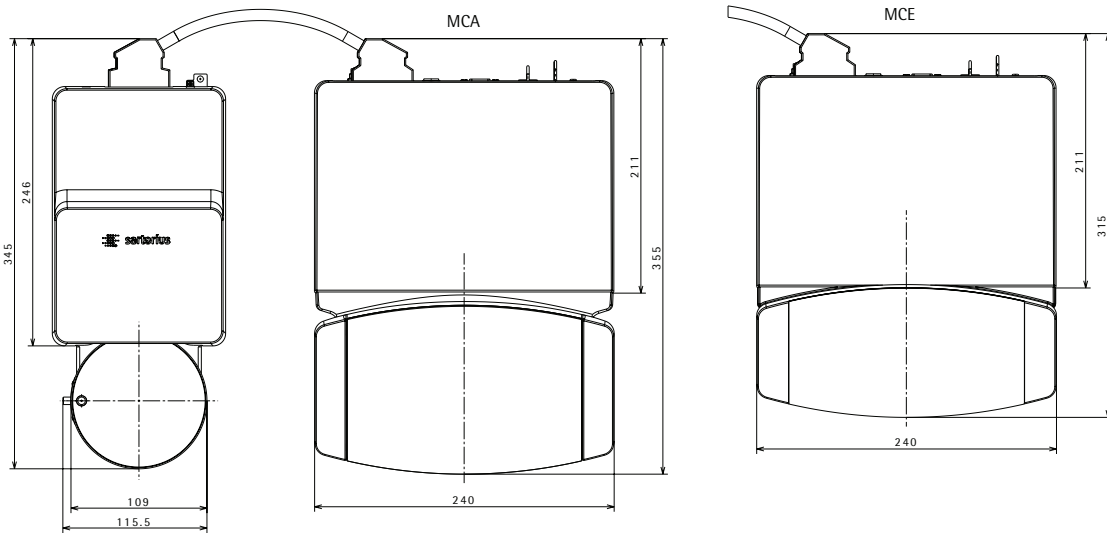
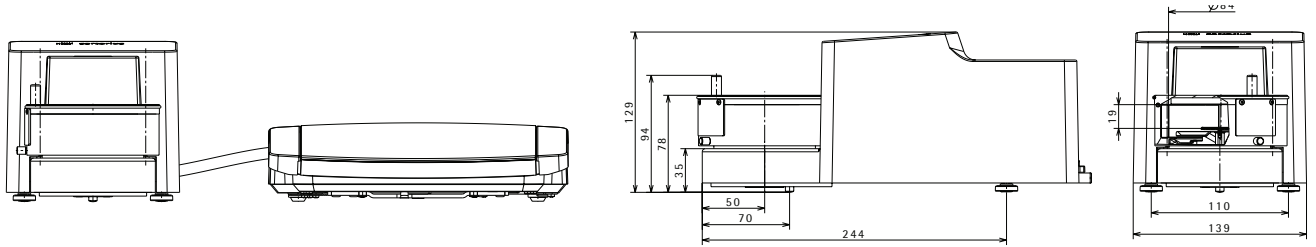

Semi-Micro Balance

All dimensions are given in millimeters

MCA

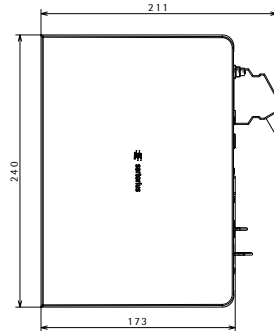
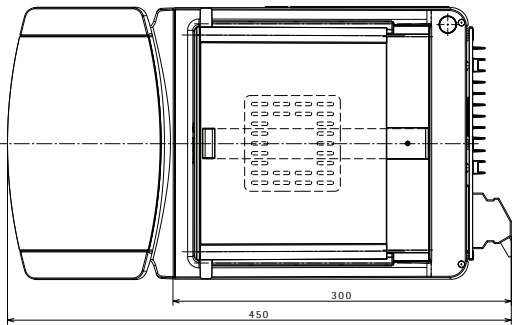
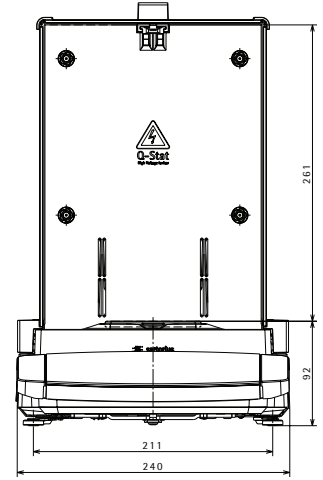
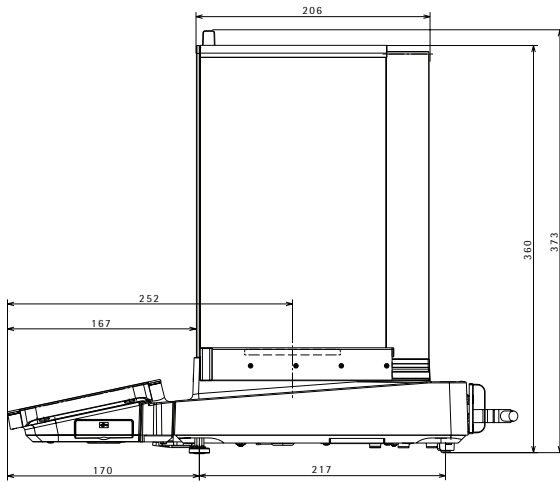

MCE

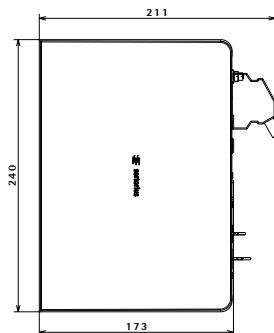
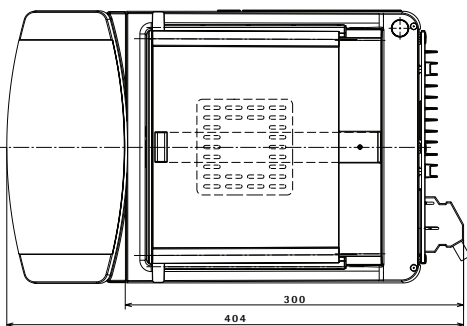
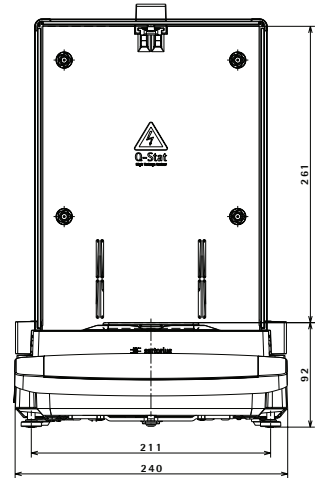
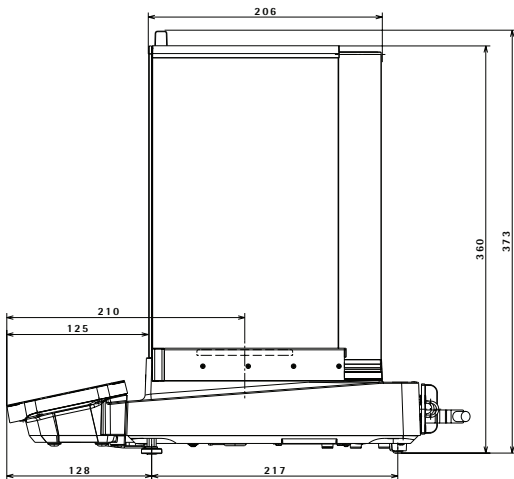

Analytical Balance

All dimensions are given in millimeters

MCA

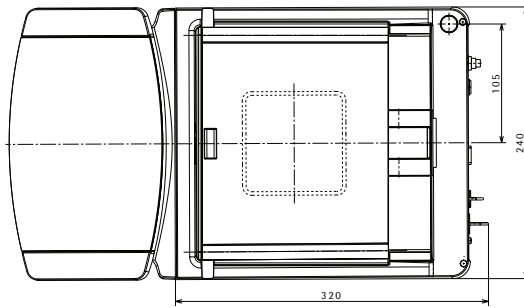
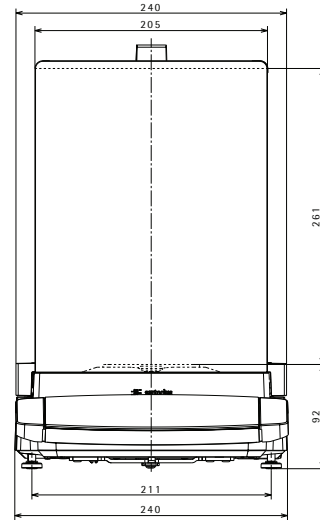
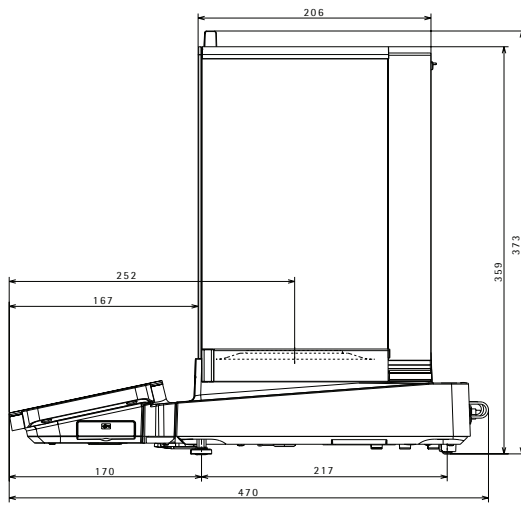

MCE

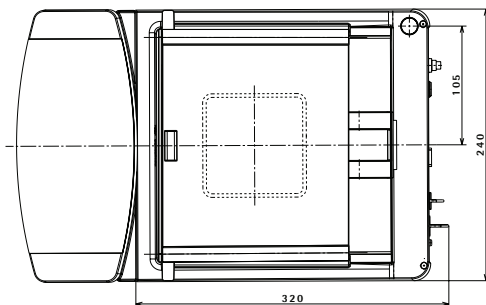
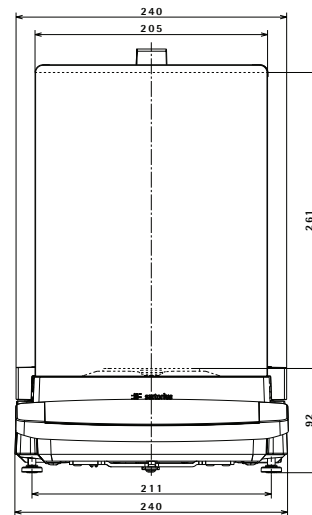
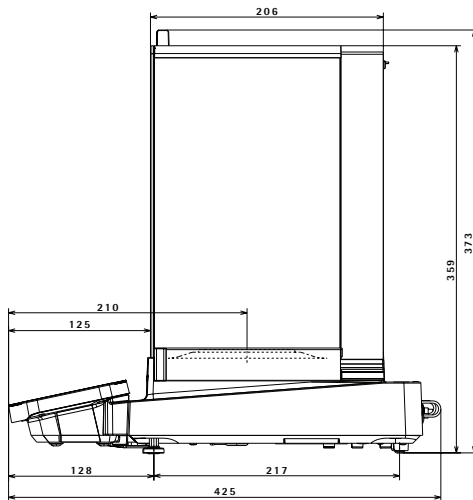

Precision Balance

All dimensions are given in millimeters

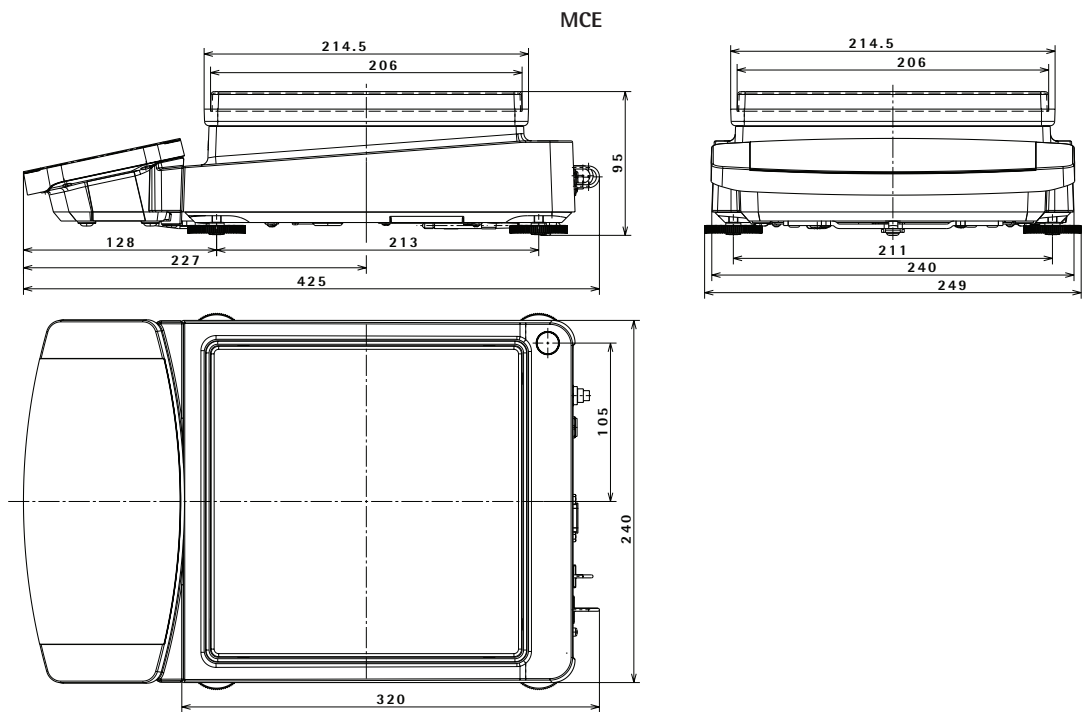
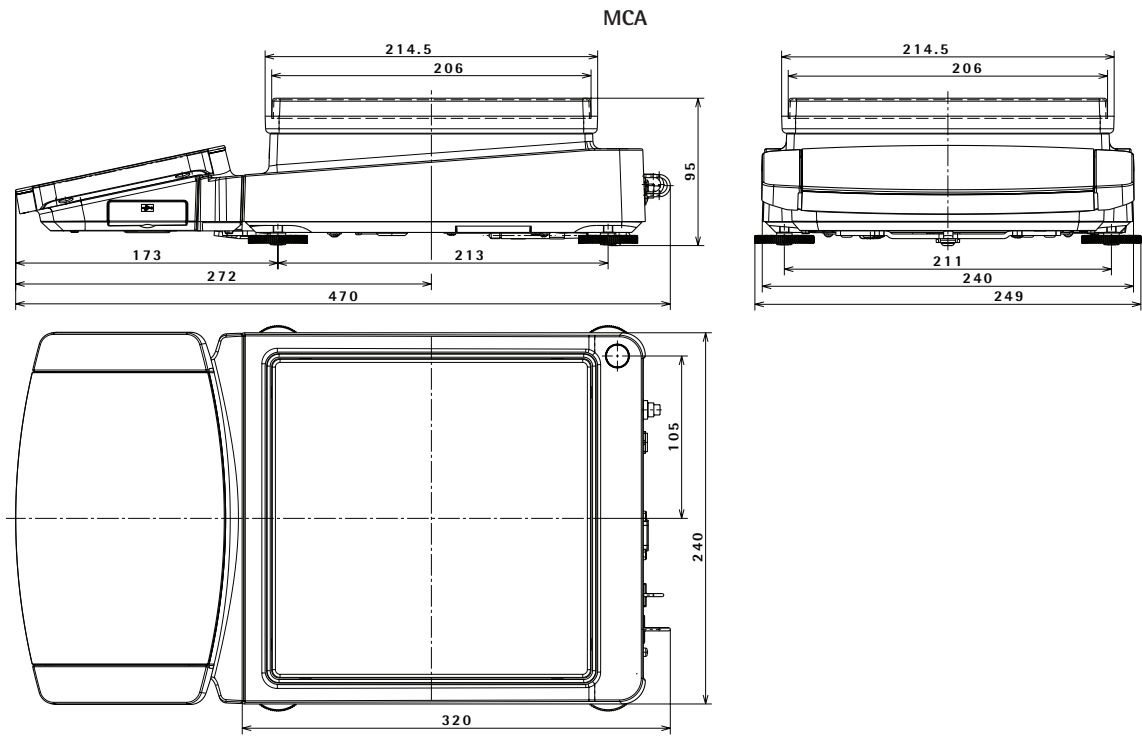

High-Capacity Balance

All dimensions are given in millimeters

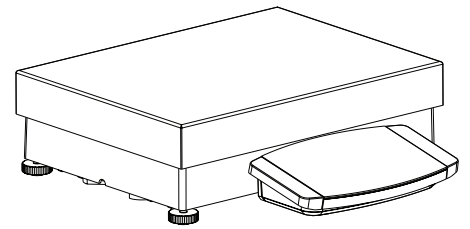
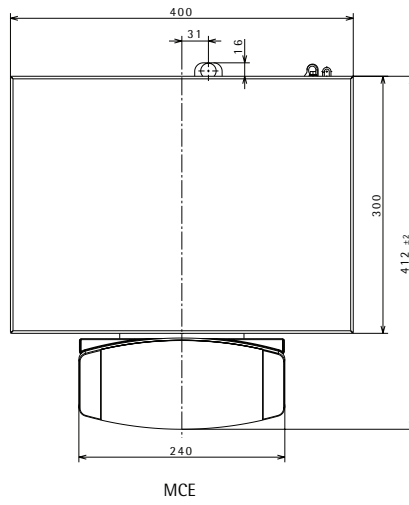
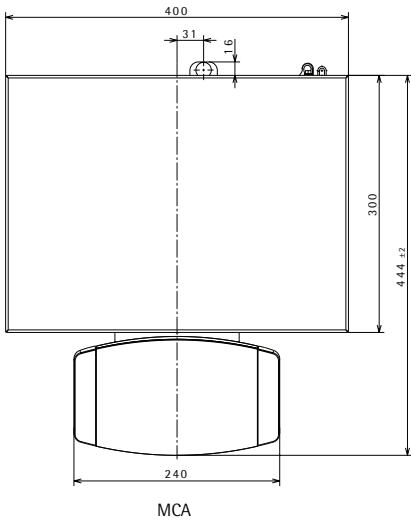
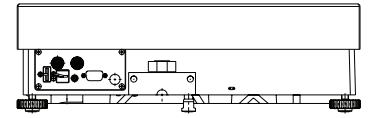
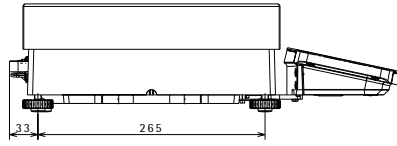
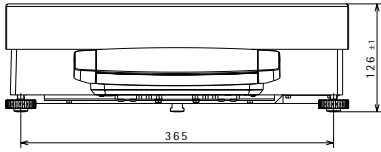

Sales and Service Contacts

For further contacts, visit www.sartorius.com

Europe

Germany

Sartorius Lab Instruments
GmbH & Co. KG
Otto-Brenner-Strasse 20
37079 Goettingen

Phone +49.551.308.0
Fax +49.551.308.3289

France & Suisse Romande

Sartorius France
2, rue Antoine Laurent de Lavoisier
ZA de la Gaudrée
91410 Dourdan

Phone +33.1.70.62.50.00
Fax +33.1.64.59.76.39

Austria

Sartorius Austria GmbH
Modecenterstrasse 22
1030 Vienna

Phone +43.1.7965760.0
Fax +43.1.7965760.24

Belgium

Sartorius Belgium N.V.
Rue Colonel Bourg 105
1030 Bruxelles

Phone +32.2.756.06.90
Fax +32.2.481.84.11

Finland & Baltics

Sartorius Biohit Liquid Handling Oy
Laippatie 1
00880 Helsinki

Phone +358.9.755.951
Fax +358.9.755.95.200

Hungary

Sartorius Hungária Kft.
Kagyló u. 5.
2092 Budakeszi

Phone +3623.457.227
Fax +3623.457.147

Ireland

Sartorius Ireland Ltd.
Unit 41, The Business Centre
Stadium Business Park
Ballycoolin Road
Dublin 11

Phone +353.1.8089050
Fax +353.1.8089388

Italy

Sartorius Italy S.r.l.
Via Torino 3/5
20814 Varedo (MB)

Phone +39 0362 5557.11
Fax +39 0362 5557.99

Netherlands

Sartorius Netherlands B.V.

Phone +31.30.60.53.001
Fax +31.30.60.52.917

info.netherlands@sartorius.com

Poland

Sartorius Poland sp.z o.o.
ul. Wrzesinska 70
62-025 Kostrzyn

Phone +48.61.6473830
Fax +48.61.6473839

Russian Federation

LLC "Sartorius RUS"
Vasilyevsky Island
5th line 70, Lit. A
199178 St. Petersburg

Phone +7.812.327.53.27
Fax +7.812.327.53.23

Spain & Portugal

Sartorius Spain, S.A.
Avda. de la Industria, 32
Edificio PAYMA
28108 Alcobendas (Madrid)

Phone Spain +34.913.586.095
Phone Portugal +351.800.855.800
Fax Spain +34.913.589.623
Fax Portugal +351.800.855.799

Switzerland

Sartorius Mechatronics Switzerland AG
Ringstrasse 24a
8317 Tagelswangen (ZH)

Phone +41.44.746.50.00
Fax +41.44.746.50.50

U.K.

Sartorius UK Ltd.
Longmead Business Centre
Blenheim Road, Epsom
Surrey KT19 9QQ

Phone +44.1372.737159
Fax +44.1372.726171

Ukraine

LLS "Sartorius RUS"
Post Box 440 "B"
01001 Kiev, Ukraine

Phone +380.44.411.4918
Fax +380.50.623.3162

Americas

USA

Sartorius Corporation
5 Orville Drive, Suite 200
Bohemia, NY 11716

Phone +1.631.254.4249
Toll-free +1.800.635.2906
Fax +1.631.254.4253

Argentina

Sartorius Argentina S.A.
Int. A. Ávalos 4251
B1605ECS Munro
Buenos Aires

Phone +54.11.4721.0505
Fax +54.11.4762.2333

Brazil

Sartorius do Brasil Ltda
Avenida Senador Vergueiro 2962
São Bernardo do Campo
CEP 09600-000 - SP - Brasil

Phone +55.11.4362.8900
Fax +55.11.4362.8901

Canada

Sartorius Canada Inc.
1173 North Service Road West, D4
Oakville, ON L6M 2V9

Phone +1.905.569.7977
Toll-Free +1.800.668.4234
Fax +1.905.569.7021

Mexico

Sartorius de México, S.A. de C.V.
Libramiento Norte de Tepotzotlan s/n,
Colonia Barrio Tlacateco,
Municipio de Tepotzotlan,
Estado de México,
C.P. 54605

Phone +52.55.5562.1102
Fax +52.55.5562.2942

leadsmex@sartorius.com

Asia Pacific

Australia

Sartorius Australia Pty. Ltd.
Unit 5, 7-11 Rodeo Drive
Dandenong South Vic 3175

Phone +61.3.8762.1800
Fax +61.3.8762.1828

China

Sartorius (Shanghai) Trading Co., Ltd.
3rd Floor, North Wing, Tower 1
No. 4560 Jinke Road
Zhangjiang Hi-Tech Park
Pudong District
Shanghai 201210, P.R. China

Phone +86.21.6878.2300
Fax +86.21.6878.2882

Hong Kong

Sartorius Hong Kong Ltd.
Unit 1012, Lu Plaza
2 Wing Yip Street
Kwun Tong
Kowloon, Hong Kong

Phone +852.2774.2678
Fax +852.2766.3526

India

Sartorius Weighing India Pvt. Ltd.
#69/2-69/3, NH 48, Jakkasandra,
Nelamangala Tq
562 123 Bangalore, India

Phone +91.80.4350.5250
Fax +91.80.4350.5253

Japan

Sartorius Japan K.K.
4th Fl., Daiwa Shinagawa North Bldg.
8-11, Kita-Shinagawa 1-chome
Shinagawa-ku, Tokyo, 140-0001 Japan

Phone +81.3.3740.5408
Fax +81.3.3740.5406

Malaysia

Sartorius Malaysia Sdn. Bhd
Lot L3-E-3B, Enterprise 4
Technology Park Malaysia
Bukit Jalil
57000 Kuala Lumpur, Malaysia

Phone +60.3.8996.0622
Fax +60.3.8996.0755

Singapore

Sartorius Singapore Pte. Ltd
10 Science Park Road,
The Alpha #02-13/14,
Singapore Science Park II
Singapore 117684

Phone +65.6872.3966
Fax +65.6778.2494

South Korea

Sartorius Korea Ltd.
8th Floor, Solid Space B/D,
PanGyoYeok-Ro 220, BunDang-Gu
SeongNam-Si, GyeongGi-Do, 463-400

Phone +82.31.622.5700
Fax +82.31.622.5799

Thailand

Sartorius (Thailand) Co. Ltd.
129 Rama 9 Road,
Huaykwang
Bangkok 10310

Phone +66.2643.8361-6
Fax +66.2643.8367



◀ www.sartorius.com